

 **UMBROSA**[®]
UNIQUE SHADE DESIGN



ECLIPSE® BY UMBROSA





ECLIPSE® BY UMBROSA



CHARACTERISTICS

- 1** Easy-to-use handle to adjust height
- 2** Easy to remove the canopy
- 3** 360° rotation of the umbrella
- 4** Protection cover included

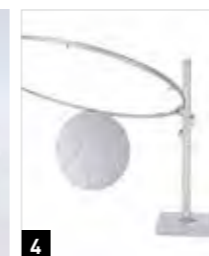

AVAILABLE COLOURS

see p. 52

TECHNICAL SPECIFICATIONS

DIMENSIONS

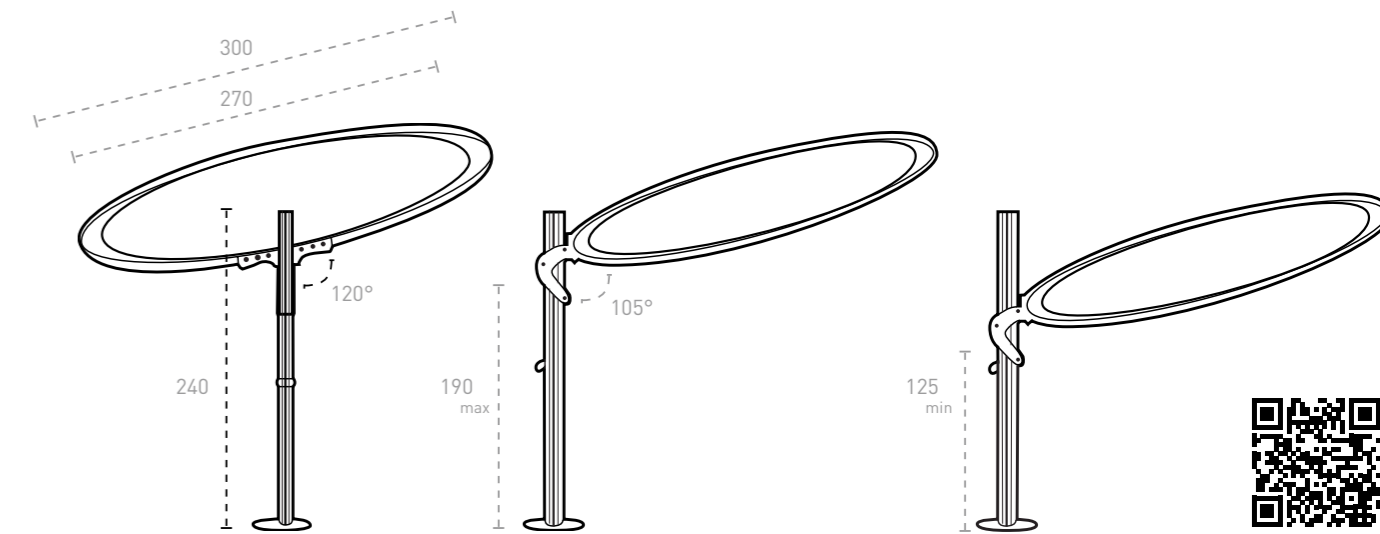

SEE HOW THIS WORKS:
[HTTP://WWW.UMBROSA.BE/VIDEO.PHP](http://www.umbrosa.be/video.php)

INSTALLATION

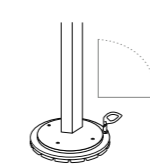

ROTATION SUPPORT**

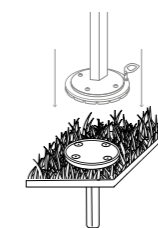

CONCRETE ANCHORAGE FOR ROTATION SUPPORT*

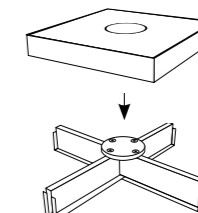

TILE BASE + COVER*

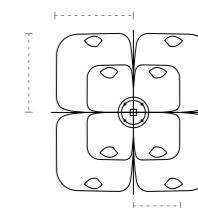

LEAFS*

**INCLUDED *OPTIONAL



INFINA® BY UMBROSA





INFINA® BY UMBROSA

CHARACTERISTICS

- 1 Easy to open with rope
- 2 Easy to "hide" the rope in pole
- 3 Stainless steel cables
- 4 Movable base
- 5 Protection cover included

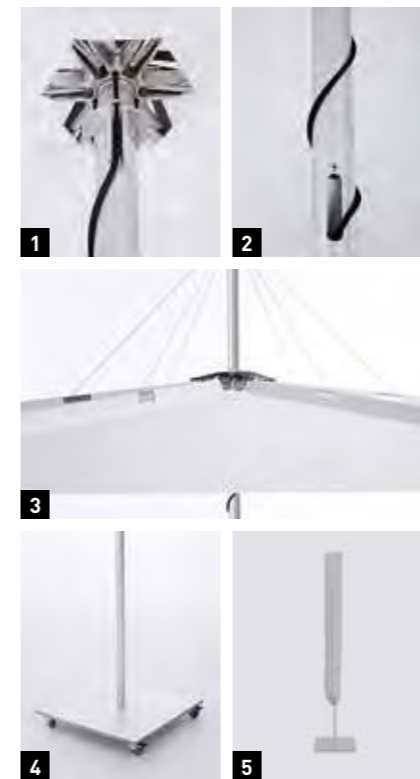

AVAILABLE COLOURS

see p. 52

TECHNICAL SPECIFICATIONS

DIMENSIONS

SQUARE

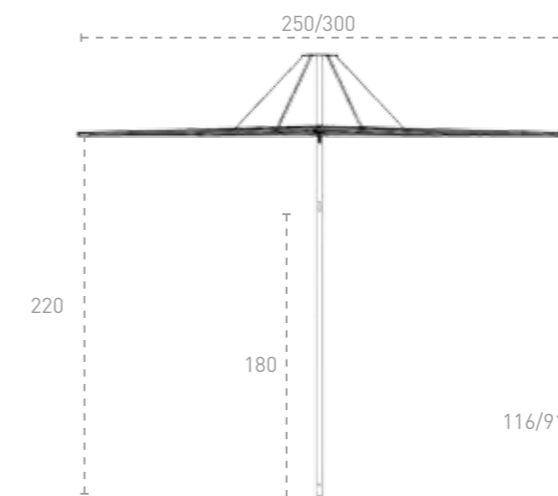

ROUND

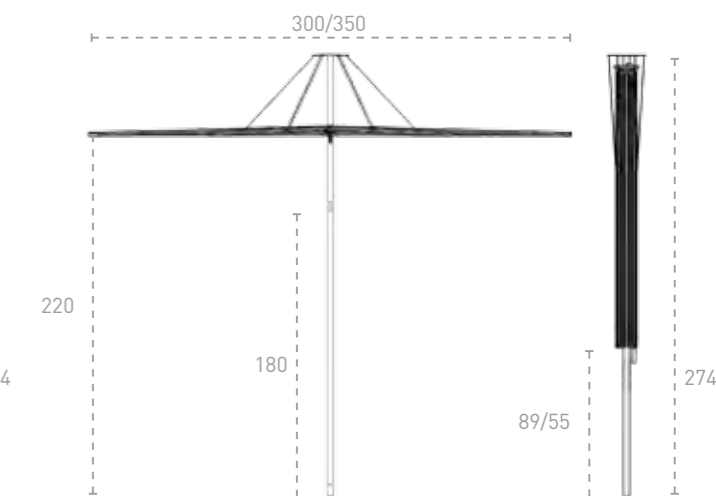

INSTALLATION

SEE HOW THIS WORKS:
[HTTP://WWW.UMBROSA.BE/VIDEO.PHP](http://www.umbrosa.be/video.php)

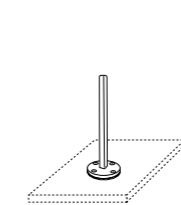

ROUND SUPPORT*

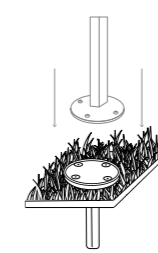

CONCRETE ANCHORAGE*

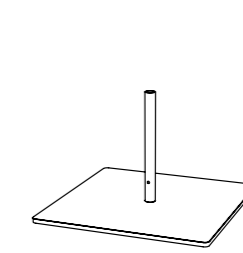

MOBILE BASE*

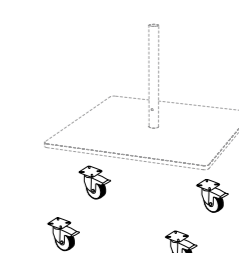

WHEEL SET*

* OPTIONAL

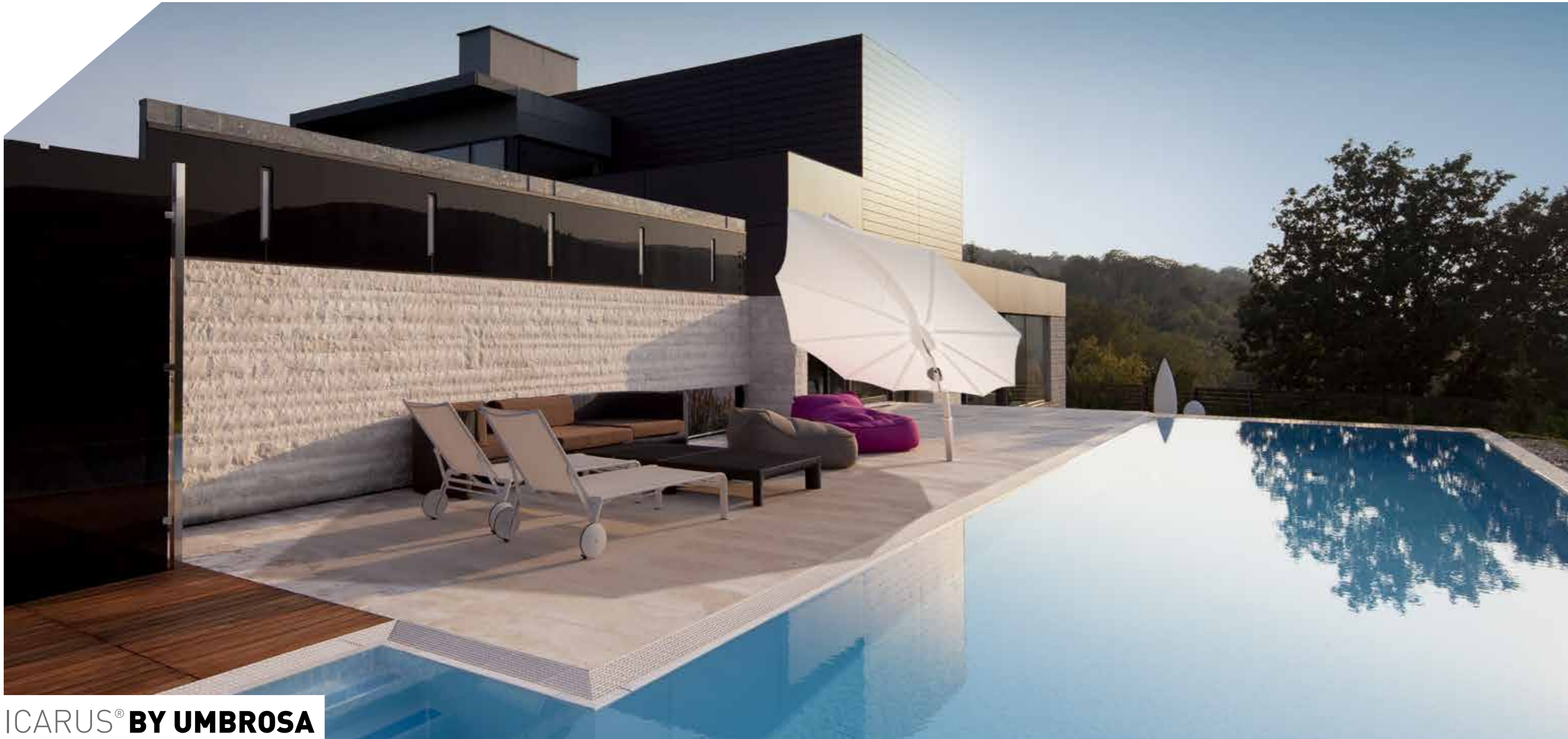

ICARUS® BY UMBROSA





ICARUS® BY UMBROSA

CHARACTERISTICS

- 1** Extendable telescopic mast
- 2** Easy to open
- 3** Smart design
- 4** 360° rotation
- 5** Protection cover included



AVAILABLE COLOURS

see p. 52

TECHNICAL SPECIFICATIONS

DIMENSIONS

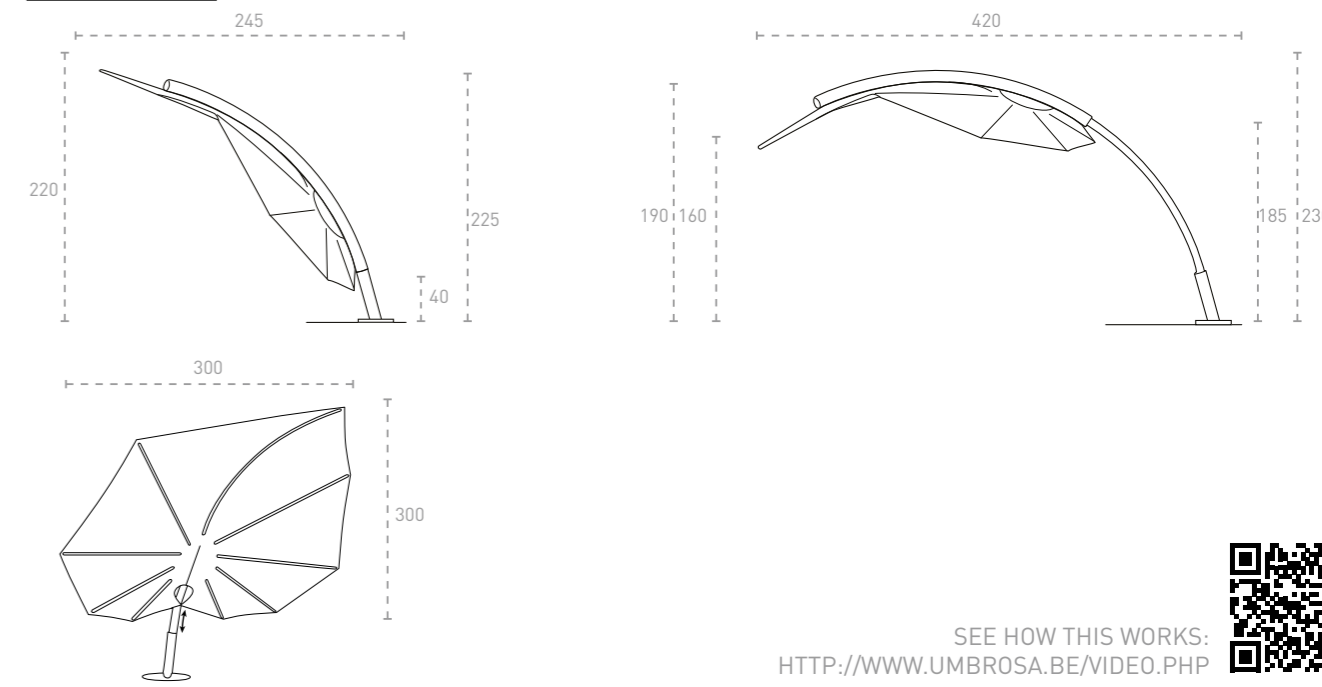

SEE HOW THIS WORKS:
[HTTP://WWW.UMBROSA.BE/VIDEO.PHP](http://www.umbrosa.be/video.php)



INSTALLATION

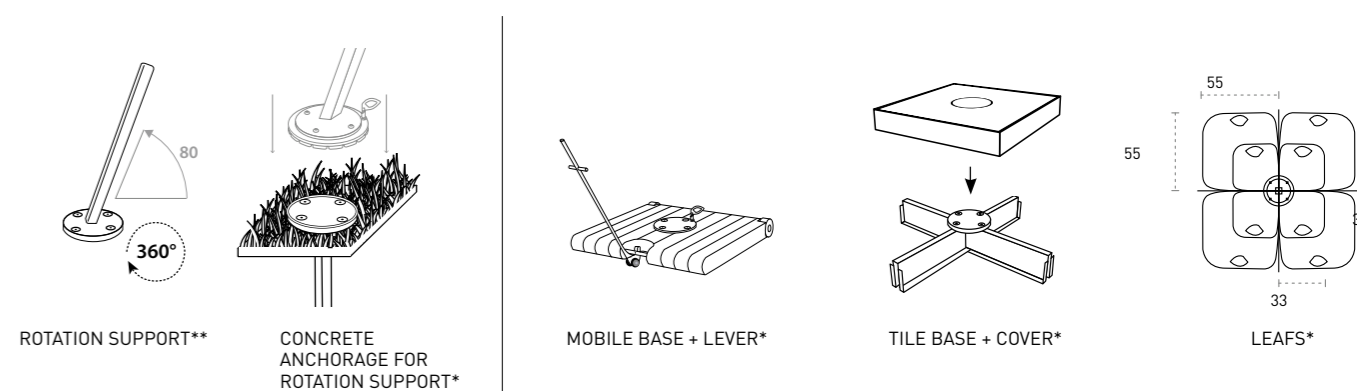

** INCLUDED * OPTIONAL



SPECTRA® BY UMBROSA





SPECTRA® BY UMBROSA



CHARACTERISTICS

- 1 Endless positioning
- 2 Easy-to-use handle for tilting
- 3 Accordion folding
- 4 360° rotation
- 5 Protection cover included

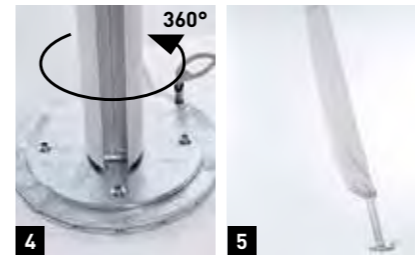
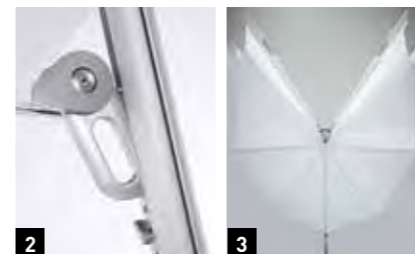

AVAILABLE COLOURS

see p. 52

TECHNICAL SPECIFICATIONS

DIMENSIONS

SQUARE

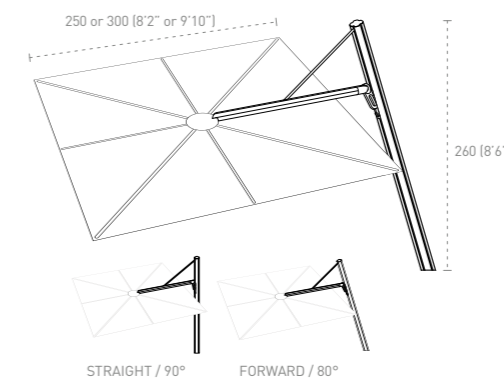

ROUND

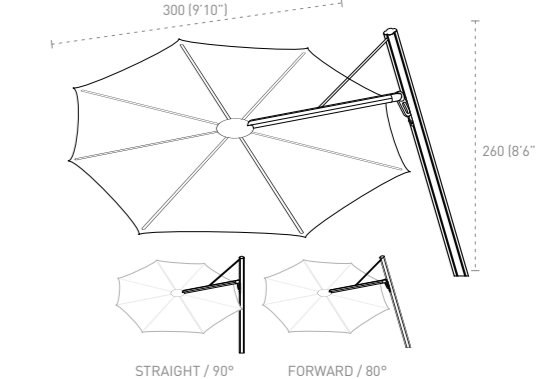

DUO

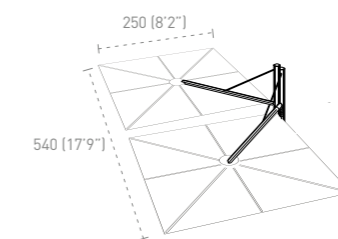

MULTI

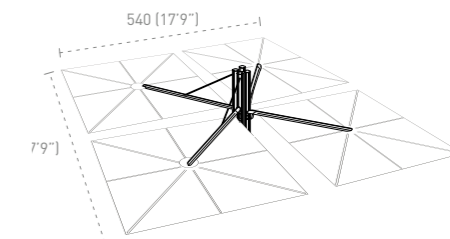

SEE HOW THIS WORKS:
[HTTP://WWW.UMBROSA.BE/VIDEO.PHP](http://www.umbrosa.be/video.php)

INSTALLATION

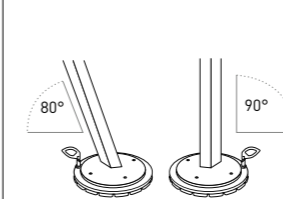

ROTATION SUPPORT**

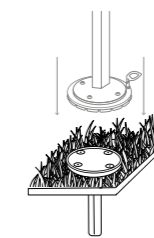

CONCRETE ANCHORAGE FOR ROTATION SUPPORT*

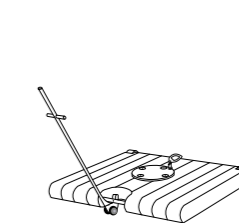

MOBILE BASE + LEVER*

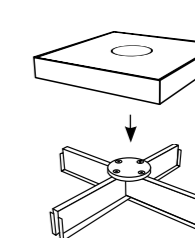

TILE BASE + COVER*

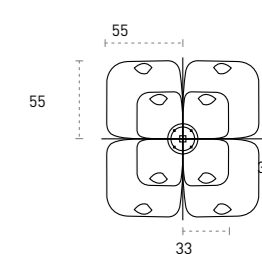

LEAFS*

** INCLUDED * OPTIONAL



RIMBU VENUS® **BY UMBROSA**





RIMBU LOTUS® BY UMBROSA

CHARACTERISTICS

- 1** Endless positions
- 2** Mobile base with adjustable handle
- 3** Protection cover included



AVAILABLE COLOURS

see p. 52

TECHNICAL SPECIFICATIONS

DIMENSIONS

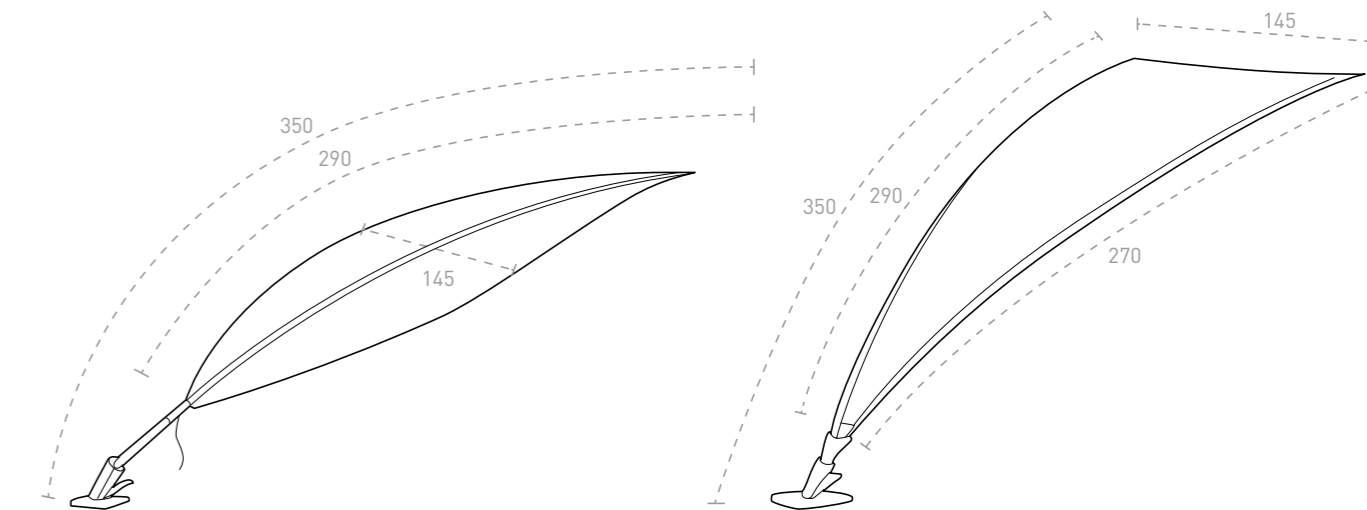

SEE HOW THIS WORKS:
[HTTP://WWW.UMBROSA.BE/VIDEO.PHP](http://www.umbrosa.be/video.php)



INSTALLATION

FIXED BASE

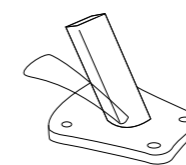

SURFACE FITTING**

MOVABLE BASE*
 weight: 26 kg / with wheels

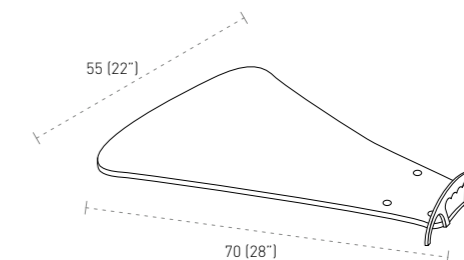

** INCLUDED * OPTIONAL



INGENUA® **BY UMBROSA**





INGENUA® BY UMBROSA

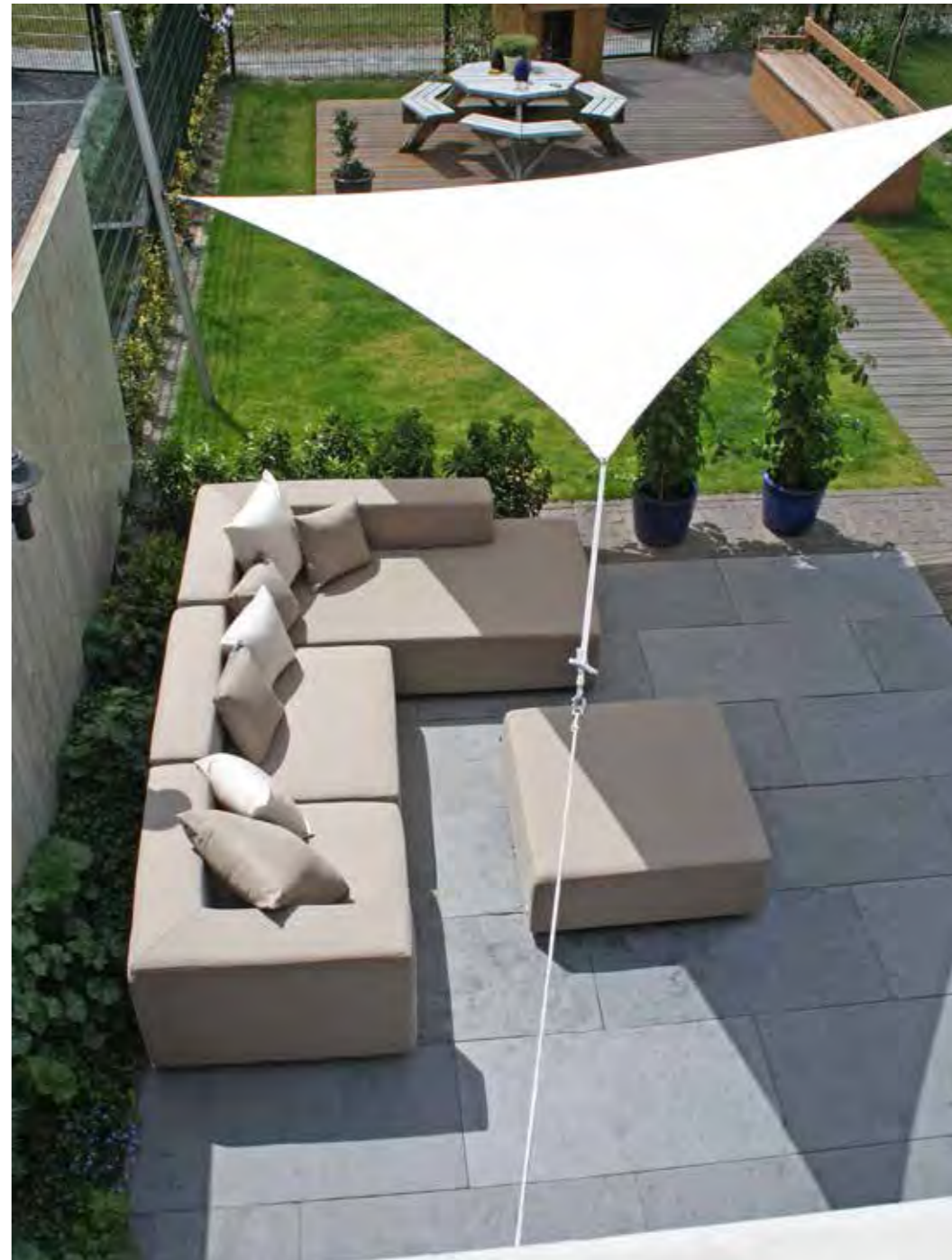

TECHNICAL SPECIFICATIONS

CHARACTERISTICS

- 1 Height adjusting slider mechanism
- 2 Quality finish
- 3 Easy tension
- 4 Easy to store with storage bag



AVAILABLE COLOURS

see p. 52

DIMENSIONS

TRIANGLE

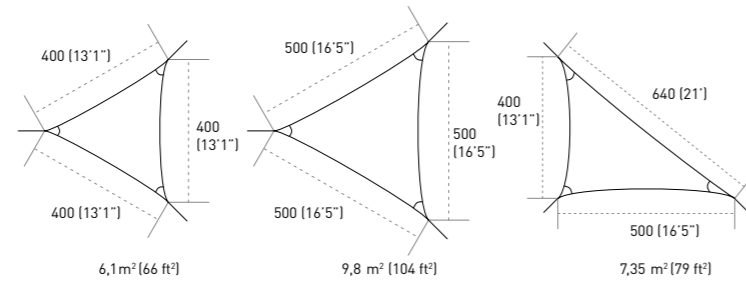

RECTANGLE

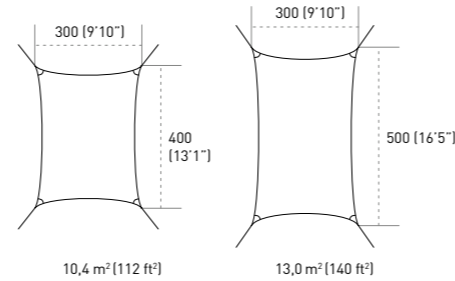

SQUARE

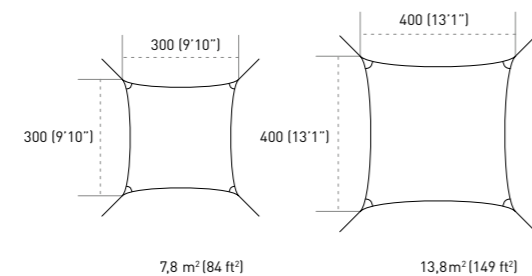

PENTA

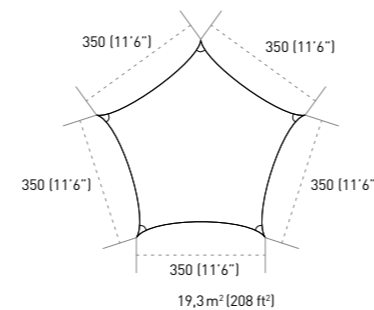

POLE INSTALLATION

POSITIONING 90°

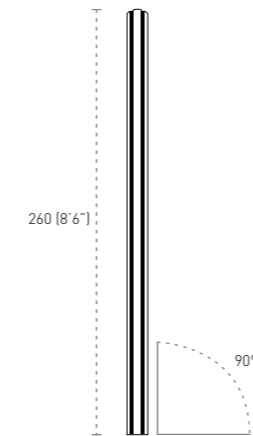

INSTALLATION 90°

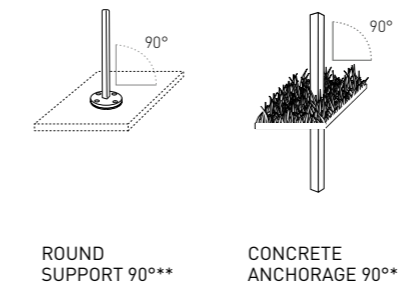

POSITIONING 75°

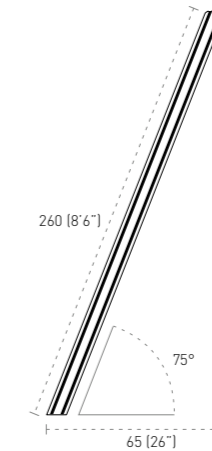

INSTALLATION 75°

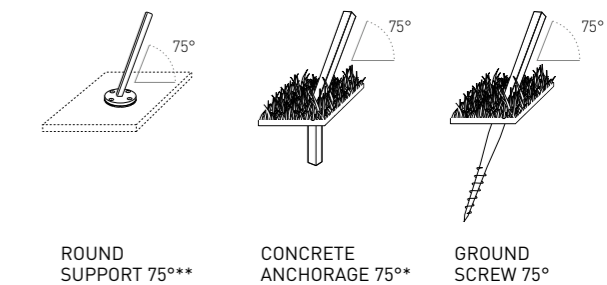

WALL INSTALLATION

WALL MOUNT

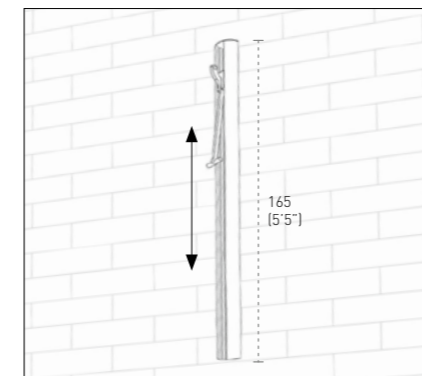

WITH FLEXIBLE SLIDING MECHANISM

WALLKIT

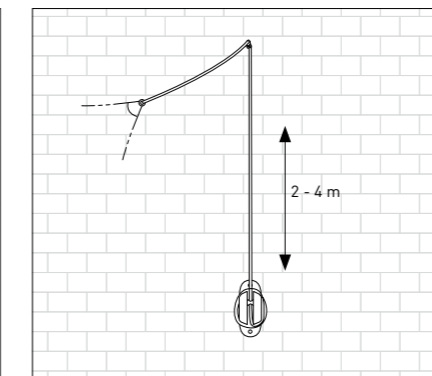

ONE FIXED HEIGHT

SEE HOW THIS WORKS:
[HTTP://WWW.UMBROSA.BE/VIDEO.PHP](http://www.umbrosa.be/video.php)



FABRICS & COLOURS

PREMIUM	Alba	Mint	Mandarine	Sunflower	Camel	Roma	Terra	Taupe	Stonegrey	Red	Nero
LIMITED EDITION	Canvas	Taupe	Granite	Olive	Orange	Lagoon	Gold	Paris red	Pink		

OLEFINE 190 G/M²



100% SUNBRELLA ACRYL 270 G/M²

